



Betonpompe Pumpmixers



Braccio/ Boom	M 28	M 29	M 31	M 35
Altezza verticale Vertical reach	27,2	28,1	30,6	34,2
Sbraccio orizzontale Horizontal reach	23,3	24,4	27	30,5
Altezza min. di apertura Unfolding height	5,9	6,2	7	6,5
N. ele./ tipo apertura N. of sections/ folding	4Z	4Z	4/Z	5Z
Diametro tubazione Pipeline diameter	100	125	100	100
Area apertura stabilizz. Outriggersmax. area	3,8/ 3,8	5 / 3,7	4,9x3,7xL	5,8x3,7L
Serbatoio acqua water tank	800	800	850	800
Capacità tamburo Drum capacity	8 - 10 mc	8 - 10 mc	8 - 10	9
Assi / axles n.	3	4	4	4
Passo /wheelbase	3.500	4.200	4200	4200

Pompante	Pumping unit	GSL	GX
Portata m ³	Output m ³	80	100
Pressione Bar	Pressure Bar	60	65
Cilindri mm	Cylinder mm	200x100	215x1100

Pompe Pumps



Boom / Braccio	H 35.5 DN125	H 36.5 DN112	M36.4 DN125	M41 DN125	M44.5 DN125	M45.6 DN125	M46.6 DN112	H 50.6 DN112
Altezza verticale Vertical reach	34,2	36	35,6	40,2	43,5	44,5	45,5	49,5
Sbraccio orizzontale Horizontal reach	30,5	32,2	32	36,5	39,8	40,7	41,7	45,7
Altezza min.apertura Unfolding height	6,7	6,7	8,5	7,6	8,5	8,3	8,3	9,2
N. elementi/ chiusura N. of sections / folding	5 Z	5 Z	4 Z	5 Z	5 Z	6	6/ZR	6/ZR
Diam. Tubazione Pipeline diam.	125	112	125	125	125	125	112	112
Max area stabilizzatori Outriggers max. area	6,3x6,8	6,3x6,8	6,3x7,5	8,5x8,5	8,5x9	8,9x9,2	8,9x9,2	10,5x10,5
Serbatoio acqua Water tank	700	700	700	1000	1000	1000	1000	1000
N. Assi Axles n.	3/4	3/4	3/4	4	4	4	4	4
Telaio Wheelbase	3800/4200	3800	4200	4200/4600	5600	4600	4600	5600
Camion Truck tot load	26/32	26/32	26/32	32	35	38	38	44

Pompante	Pumping unit	2315 2320	2320H
Portata m ³	Output m ³	120	150
Pressione Bar	Pressure Bar	76	76
Cilindri mm	Cylinder mm	230x1500 230x2000	230x2000

M28.4 DN100

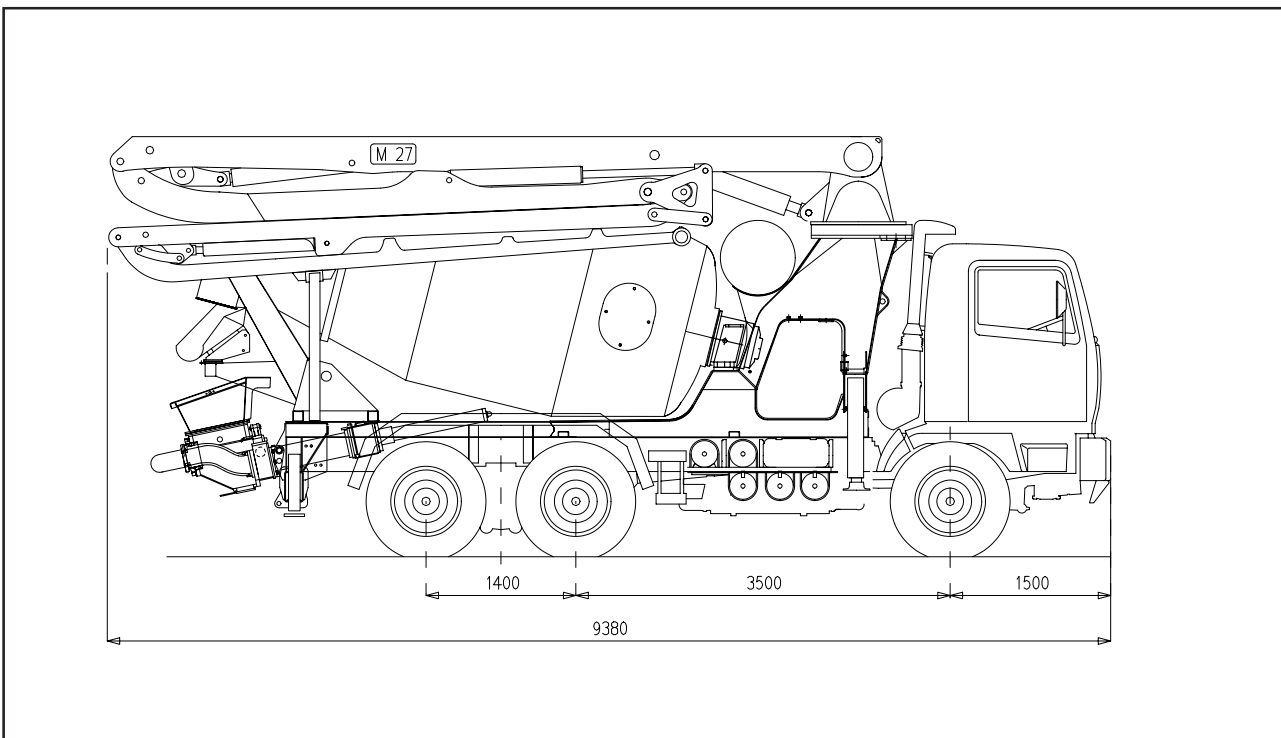

M31.4 DN100

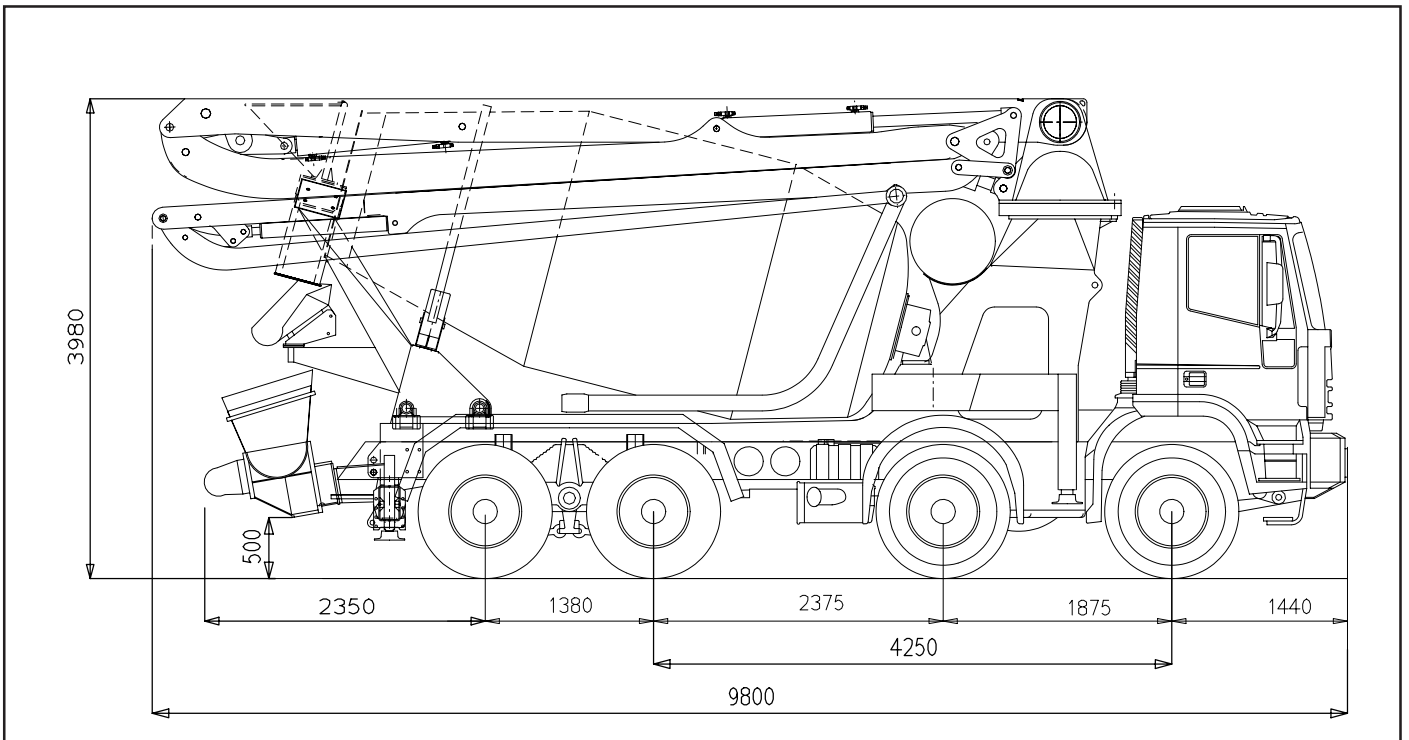

M35.5 DN100

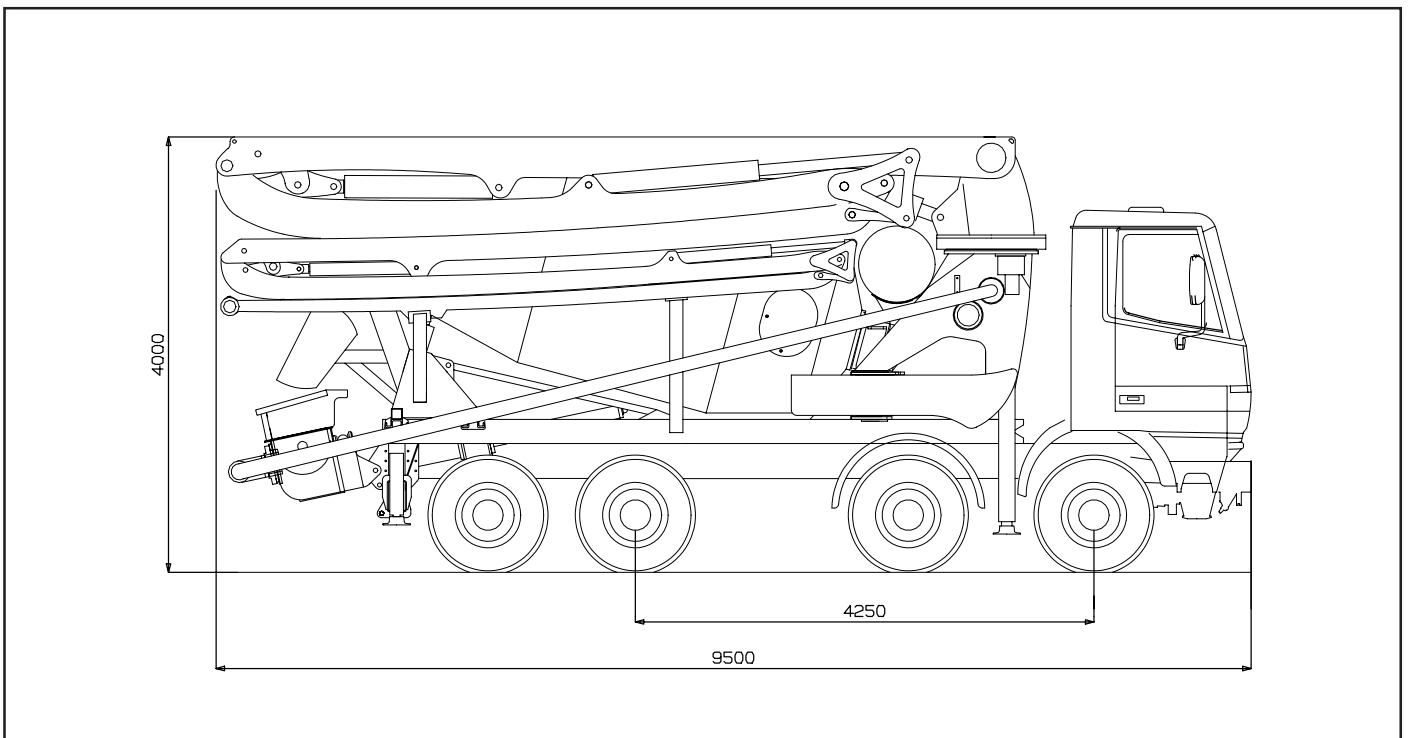

M36.4 DN125

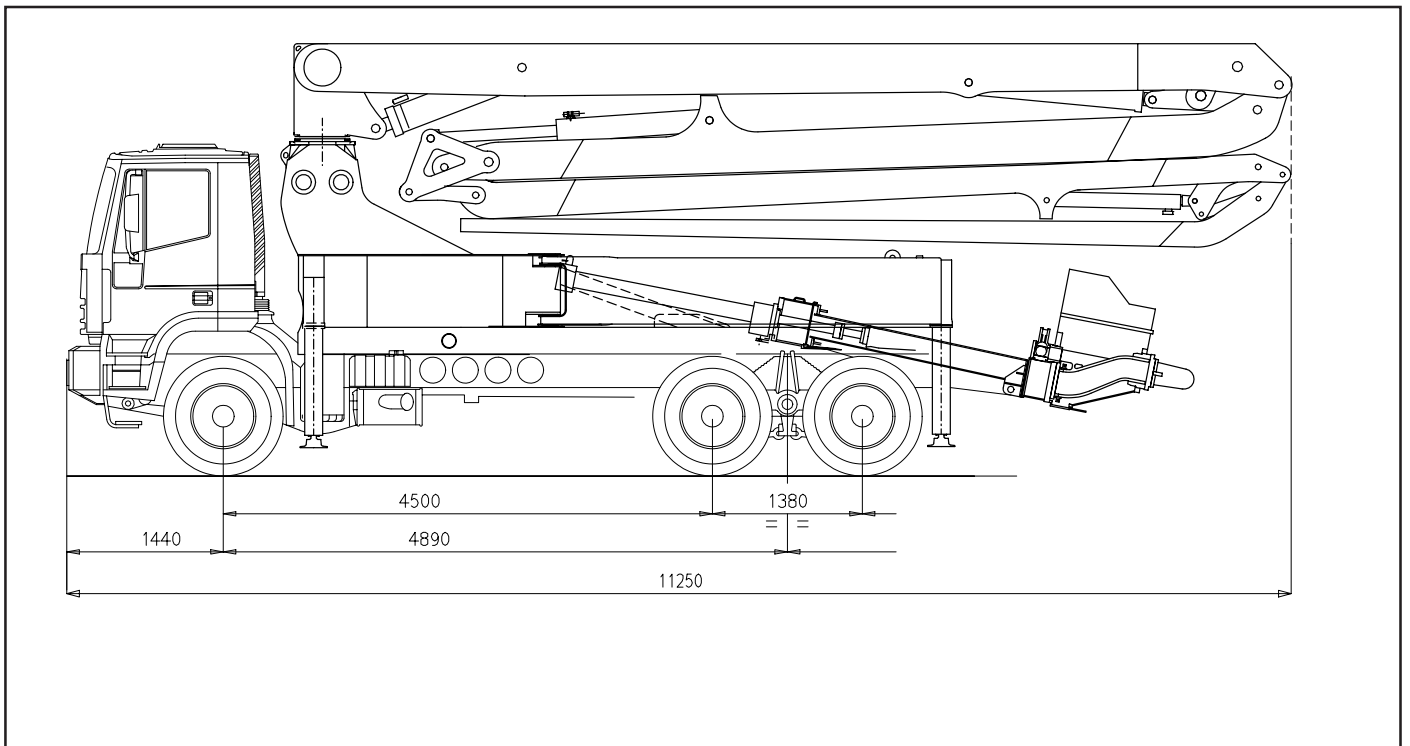

M35.5 DN125 - M36.5 DN112

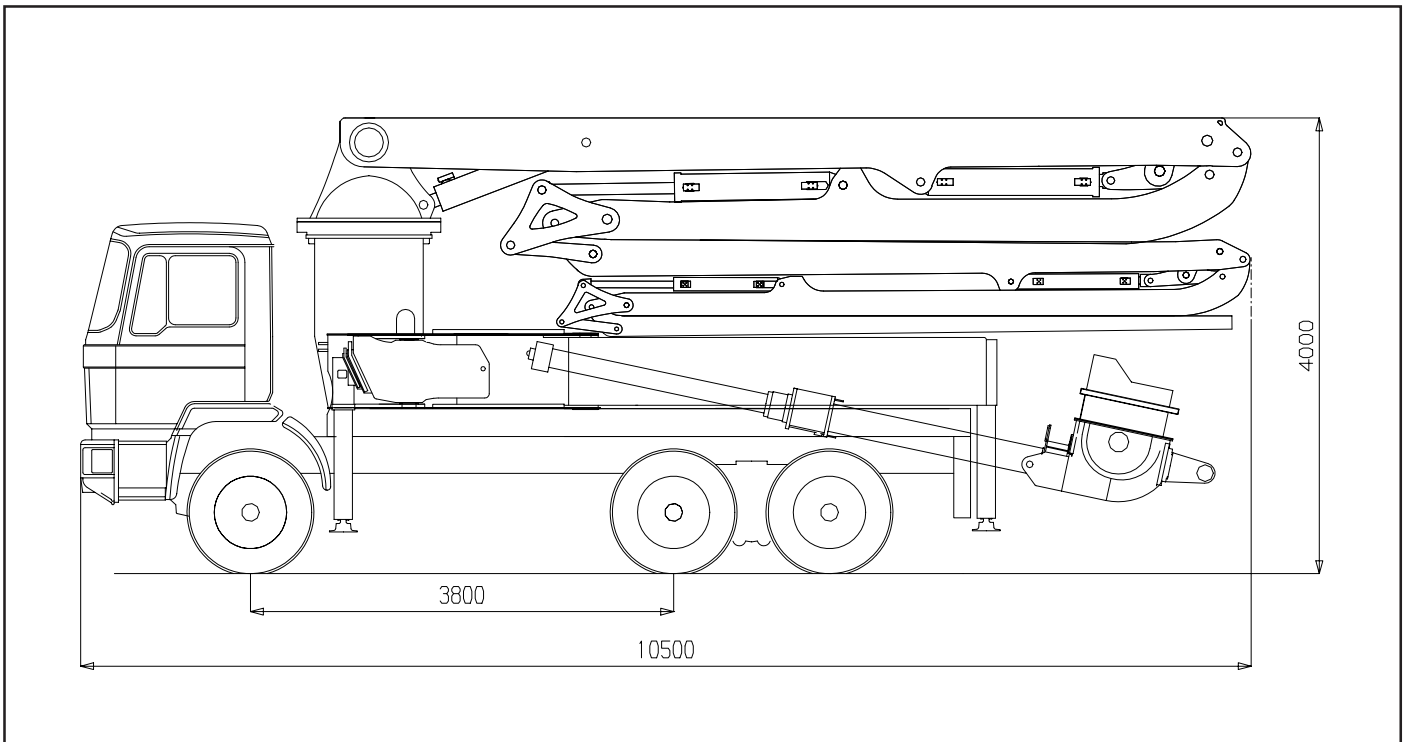

M45.6 DN125

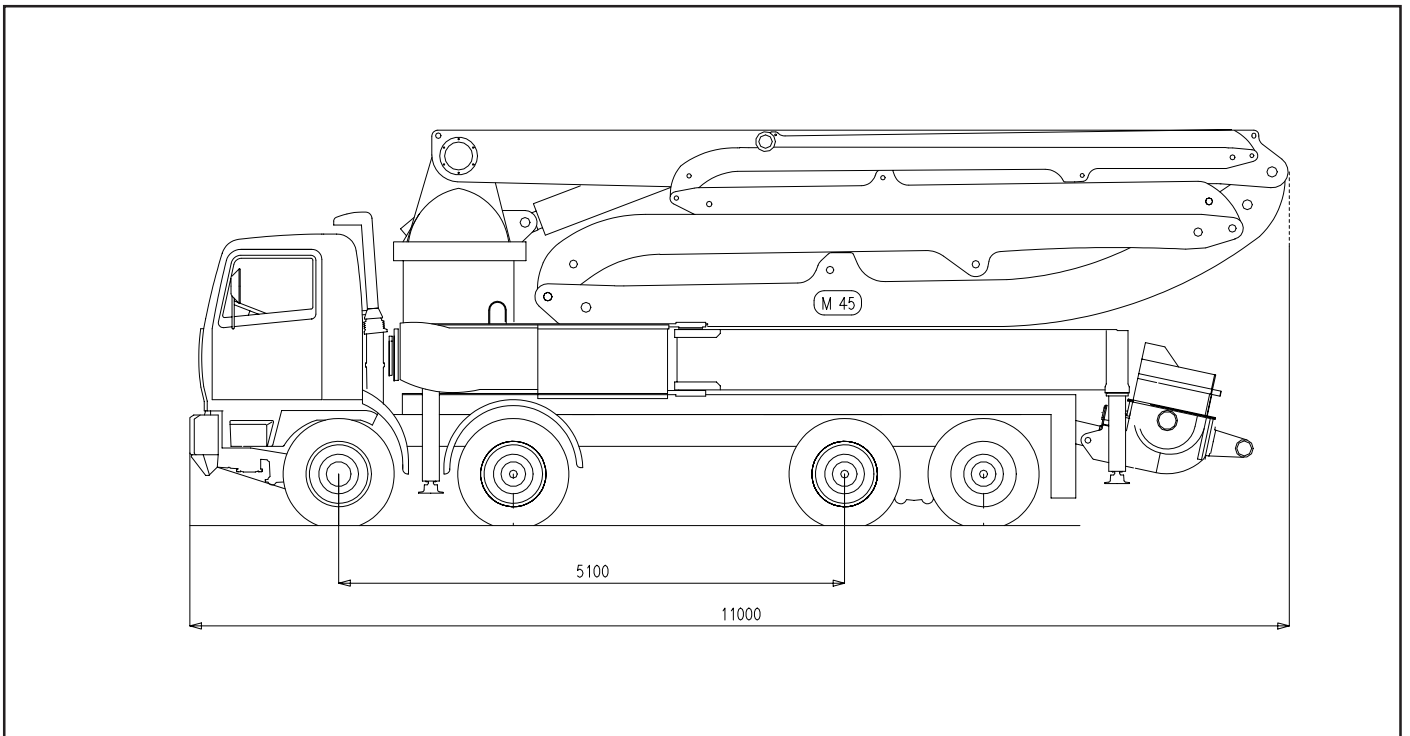

M46.6 DN112

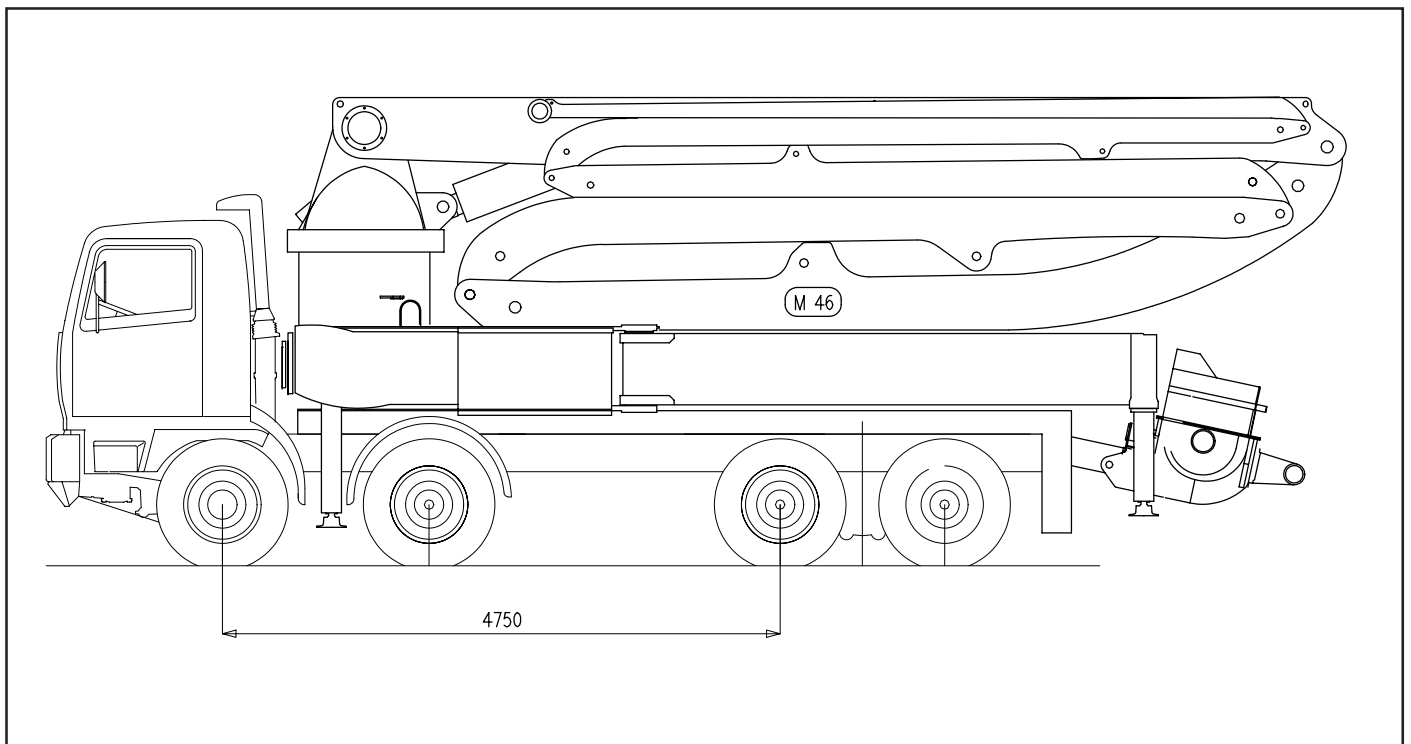

M50.6 DN 112

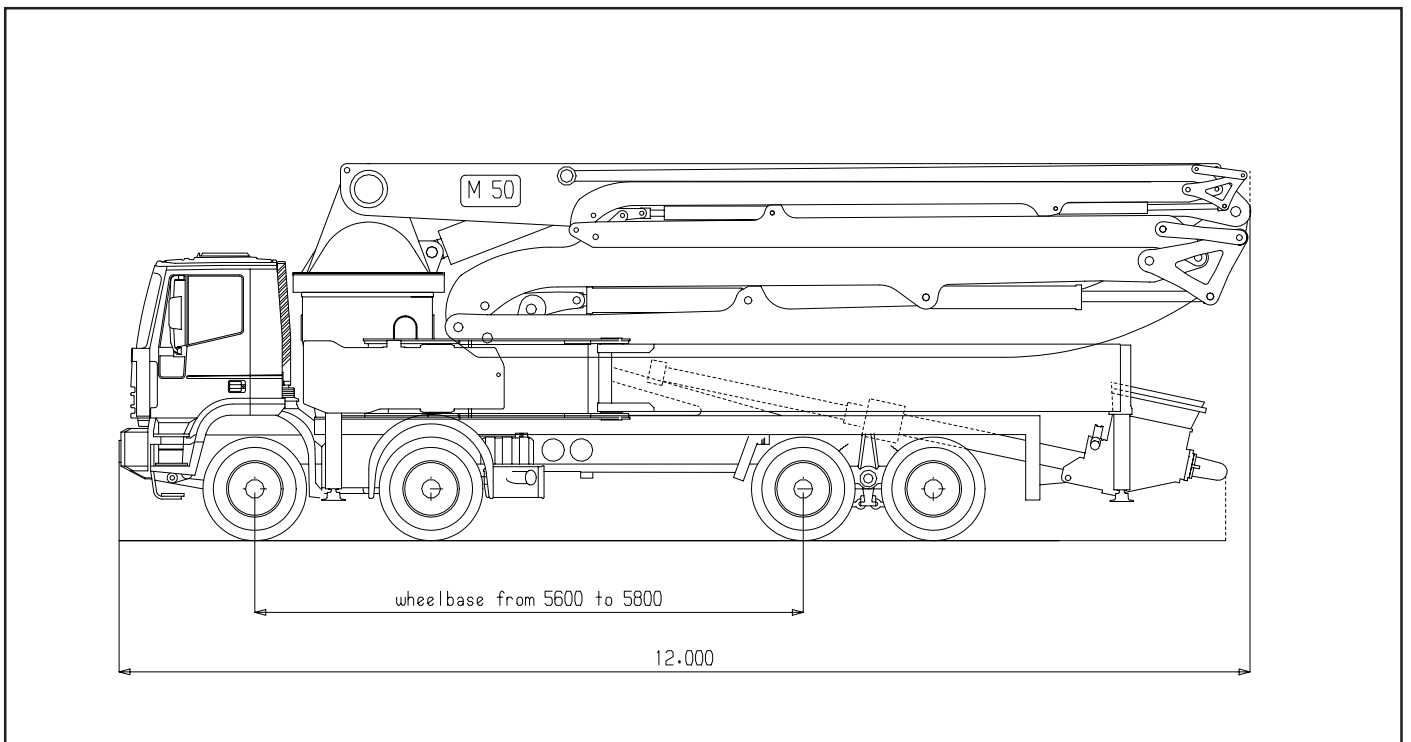

Spritz Beton



Boom Robot C84

Boom	2 sections +hydraulic folding
max. vertical reach	m 12
max. horizontal reach	m 9
length first element	m 4,2
length second element	m 2,5+2
Slewing range	360°
Front rotation	200°
Base trailer displacement	m 3,5
boom top hydraulic stretch	m 1,5
spraying lance	controlled swinging exit diameter mm 65
control	direct electro hydraulic
outriggers	2 rear side hydraulic
max hydraulic pressure	300 bar
electric circuit tension	V 24

Pumping group 2060 K

Output	30 m ³ /h
Max pressure on concrete	50 bar
N. of pumping cylinders	2
Cylinders dimensions	200 x 570 mm
Exit pipeline diameter	6"
Additive tank	l 1500
Additive heating	by electric resistance (OPTIONAL)
Water tank	l 500
Assembling on chassis	2 axles wb min. 4500
Assembling on chassis	3 axles wb min. 3500
Power electric engine	45 kW
Power take off	according to the gear

POMPE CARRELLATA TRAILER PUMP



Dati tecnici gamma standard pompe carrellate Poker Technical features standard range poker trailer pumps

Modello Model	2060-D		2010-D		2015-D-L		2020-D		2230-D	
Resa m3 Output	27	19	65	50	85	60	100	60	130	100
Pressione bar Pressure	50	70	50	70	50	70	70	120	54	90
Cilindri diam. Mm Cylinder - diam. mm	200x570		200x800		200x1500		200x2000		230x2000	
Cicli al minuto Strokes x min.	25	18	42	33	30	21	27	16	27	20
Potenza in kw Power required	40		60		90		148		148	
Serbatoio acqua litri Water tank	150		150		150		150		150	
Serbatoio olio litri Oil tank	150		250		300		400		400	
Serbatoio gasolio litri Fuel tank	150		250		300		400		400	
Capacità tramoggia m3 Hopper capacity	0,3		0,4		0,4		0,5		0,5	
Tubo uscita diam. Mm Pipeline outlet	150		150		150		180		180	
Peso kg. Net weight	3000		3500		4000		5700		6100	
Dimensioni m Overall dimensions	5,3x2x2		5,3x2x2		6x2x2		6x2x2		6x2x2	

Mixers



model	small	medium	large
output m3	8	10	12
geometric volume	12,5	14,5	17
drum inclination °	13	13	13
rotation speed	0/17	0/17	0/16
weight pto model	4300	4500	4900
weight with sep. Engine	4800	5000	5400
dimensions (LxHxW)	6x2,6x62,5	6x2,7x2,5	7x2,6x2,5
water tank	1000	1000	1000/1200
water pump output	350	350	350
pollers	2	4	4
gearbox torque	5000	5000	6000
bearing capacity	26	26/33	32/40
axles n.	3	3	4
wheelbase	3200	3200/3500	4200